

Fig 158: Corporation Clamp

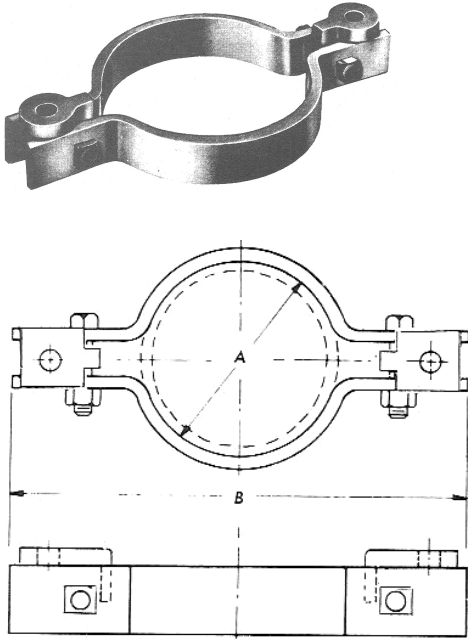

FIG 158

Material: Steel

Service Application:

Designed to restrain the caulked joints on cast iron Bell and Spigot water mains. Corporation Clamp [Fig 158](#) includes only the two half bands and two bolts and nuts. Corporation Clamp Washer, [Fig 258](#) is to be ordered separately; two for each clamp. Bolts have extra length thread to allow their use either on American Water Works Association Class C or D pipe, or on Super DeLavaud centrifugally cast pipe.

Finish:

Black or galvanized.

Ordering:

Specify size, figure number and finish. Corporation Clamp Washers, [Fig 258](#), must be ordered separately, two for each clamp.

SIZE INCHES	A	B	STOCK	ROD SIZE
4	5	12 1/8	1/2 x 2	3/4
6	7 1/16	14 3/8	1/2 x 2	3/4
8	9 3/16	16 5/8	1/2 x 2	3/4
10	11 3/8	18 7/8	1/2 x 2	3/4
12	13 1/2	21 1/4	1/2 x 2	3/4
14	15 1/4	25 1/2	3/4 x 3	1
16	17 7/8	28	3/4 x 4	1 1/8
18	20	31 1/2	3/4 x 4	1 1/4
20	22 1/8	33 3/4	3/4 x 4 1/2	1 3/8
24	26 3/8	39 3/4	3/4 x 5	1 1/2

PROJECT INFORMATION	APPROVED
JOB:	NOTES:
ADDRESS:	
CONTRACTOR:	
ENGINEER:	
DATE:	
APPROVED _____	NOT APPROVED _____ APPROVED AS NOTED _____